



CFS FACT SHEET – Building and using pizza ovens.





For full details on wood fired pizza ovens, please see the “Wood Fired Pizza Ovens Code of Practice” on the CFS website.

Using Pizza Ovens

During the Fire Danger Season

Type of Pizza Oven	Can I use it during the Fire Danger Season?	
 Gas or Electric	Yes	But only if you have: <ul style="list-style-type: none"> a four metre cleared space around and above the gas fire or electric element a responsible person in attendance at all times (see details over on “supervision”) an adequate agent to extinguish the fire at hand
 Wood Fired	Yes	But only if you have: <ul style="list-style-type: none"> a four metre cleared space around and above the pizza oven (see picture over) a responsible person in attendance at all times (see details over on “supervision”) an adequate agent to extinguish the fire at hand AND <ul style="list-style-type: none"> it is in a properly constructed pizza oven (see below) OR you have obtained a Schedule 9 Permit from your local Council

Total Fire Ban Days

Type of Pizza Oven	Can I use it on a Total Fire Ban Day?	
 Gas or Electric	Yes	But only if you have: <ul style="list-style-type: none"> a four metre cleared space around and above the gas fire or electric element a responsible person in attendance at all times an adequate agent to extinguish the fire at hand And it is used: <ul style="list-style-type: none"> within 15 metres of domestic premises, OR on a coastal foreshore
 Wood Fired	No	Unless you have obtained a Schedule 10 Permit from your local Council

Building and using a Wood Fired Pizza Oven

The key to correct construction of a wood fired pizza oven is to prevent any sparks and embers from escaping to start a fire. You can do this by ensuring:

The flue:

- is a minimum of 1.2 metres in length
- complies with Australian Standard 2918
- is topped with an effective spark arrester (that complies with Australian Standard 1019)

The construction of the oven:

- does not allow any burning material (including sparks and embers) to escape. This includes burning chambers and ventilation holes



CFS FACT SHEET – Building and using pizza ovens.



The location of the oven:

- has a minimum clearance from any flammable materials. This includes:

Above the oven: four metres

Behind the oven: 600mm

If you can't have 600mm clearance behind the oven, then use a non-combustible barrier (such as a brick or cement wall) no closer than 300mm to the oven

Risk area (in front of and to the sides of the oven): four metres

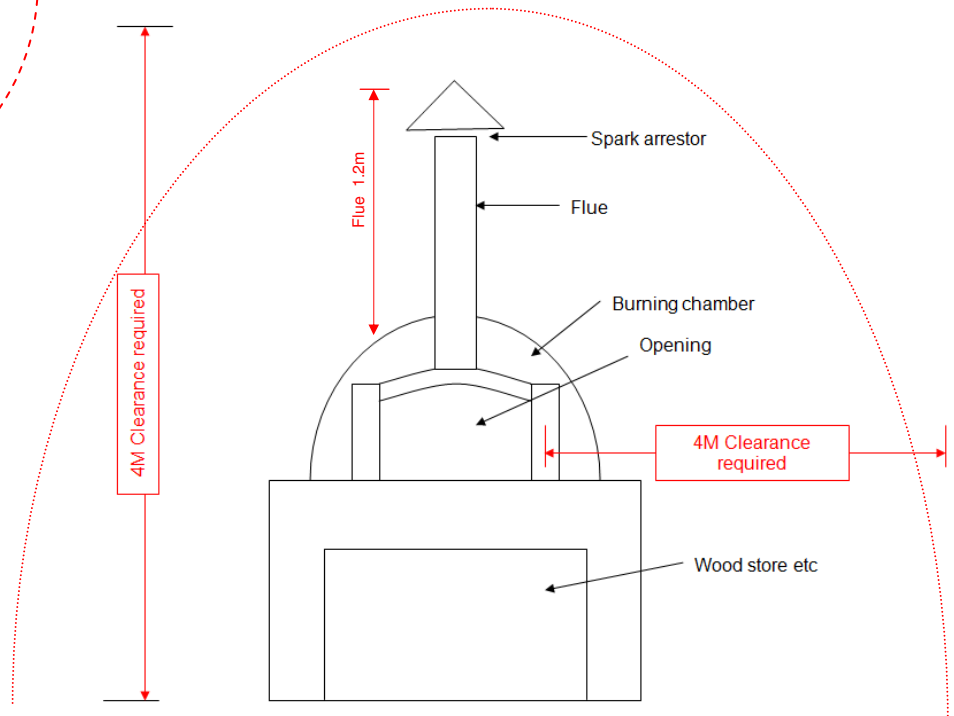
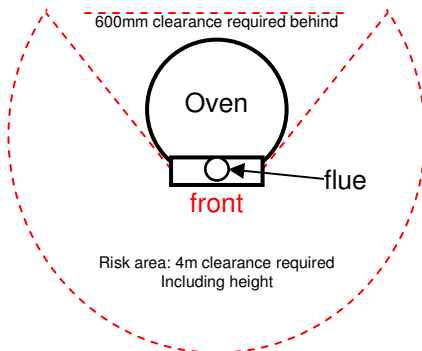

NOTE: The 4m clearance in height is from ground level and applies to a 180 degree arc surrounding the pizza oven.

Supervision of the oven:

- is constant from the time the oven is lit to the time it is completely extinguished
- is performed by someone who is able to control the fire. This means that they must be able bodied, of suitable age, and not have their judgement impaired by drugs, alcohol or medication.

Extinguishing agents

- are present at all times
- are suitable for putting out the fire. This may include a hose connected to a tap or pressurised water system, a knapsack (compliant with Australian Standard 1687-119), an dry chemical or CO₂ extinguishers (compliant with Australian Standard 1841.2-1997).

